

ACTwatch

Evidence for Malaria Medicine Policy

The private sector distribution chain of antimalarials and RDTs in Zambia

Cynthia Changufu on behalf of LSHTM



Background

- In 2002, Zambia adopted ACTs as first-line malaria treatment
- Private sector plays an important role in providing access to ACTs
- Price & availability of antimalarials in the private sector is largely determined by what happens at higher levels of the distribution chain
- National Malaria Control Strategy advocates use of RDTs for improved case management

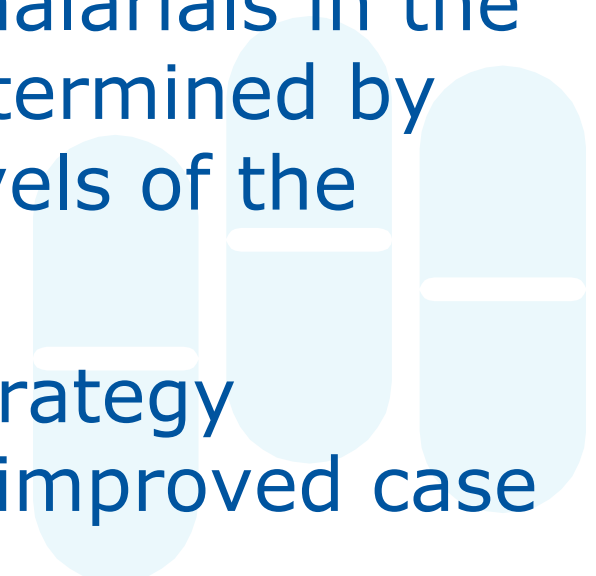

Supply Chain Study Objectives

1. Develop maps of the private sector distribution chain for antimalarials and RDTs
2. Estimate mark-ups for antimalarials and RDTs
3. Examine factors affecting drug selection, volumes & price

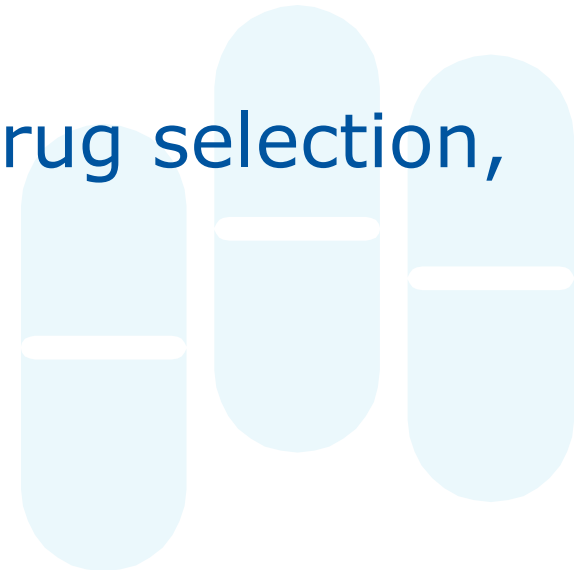

Methods

- Review of key documents
- In-depth interviews with key stakeholders
- Nationally representative structured survey administered to drug wholesalers
 - Data collected February to May 2009
 - 57 wholesalers (WS) identified in Zambia
 - Sample selected by tracing back suppliers of antimalarial retailers/outlets from 38 sub-districts across the country

Antimalarial Distribution Chain Interactions

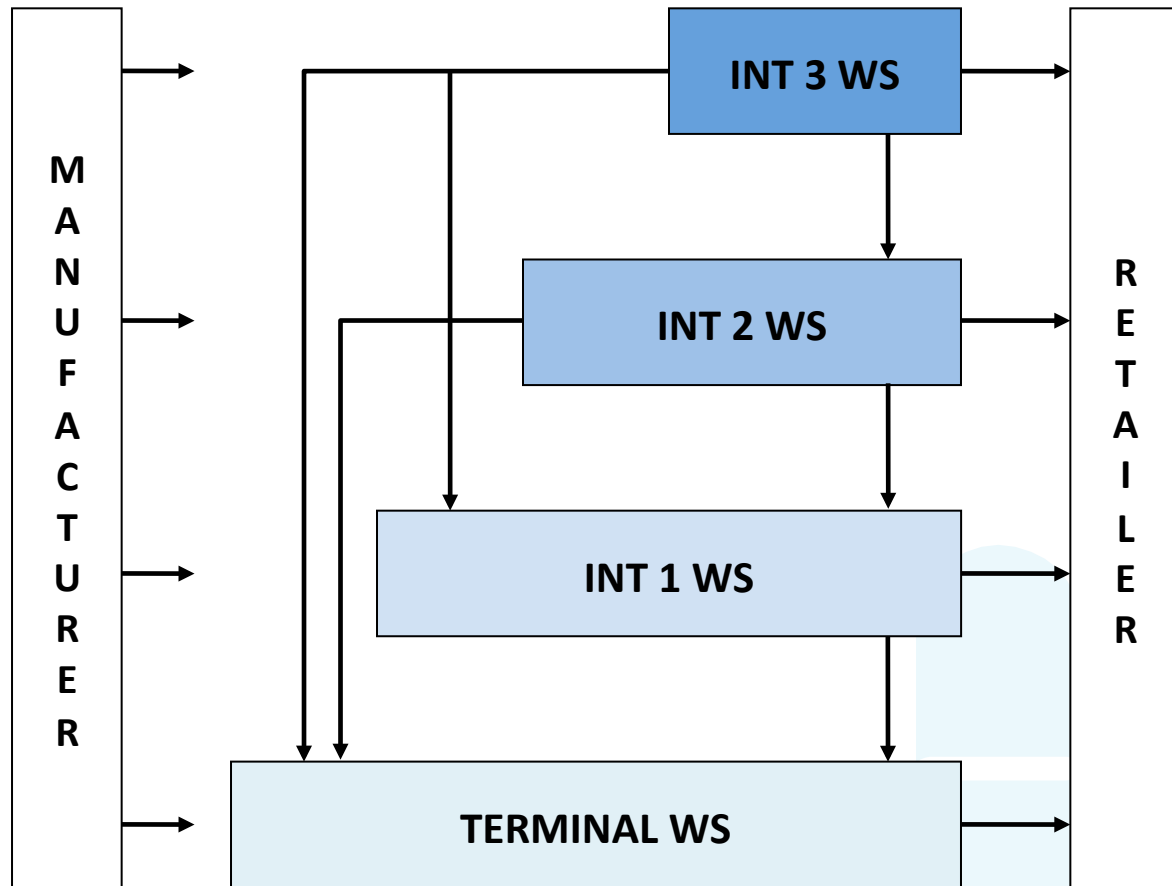

Antimalarial Distribution Chain Interactions

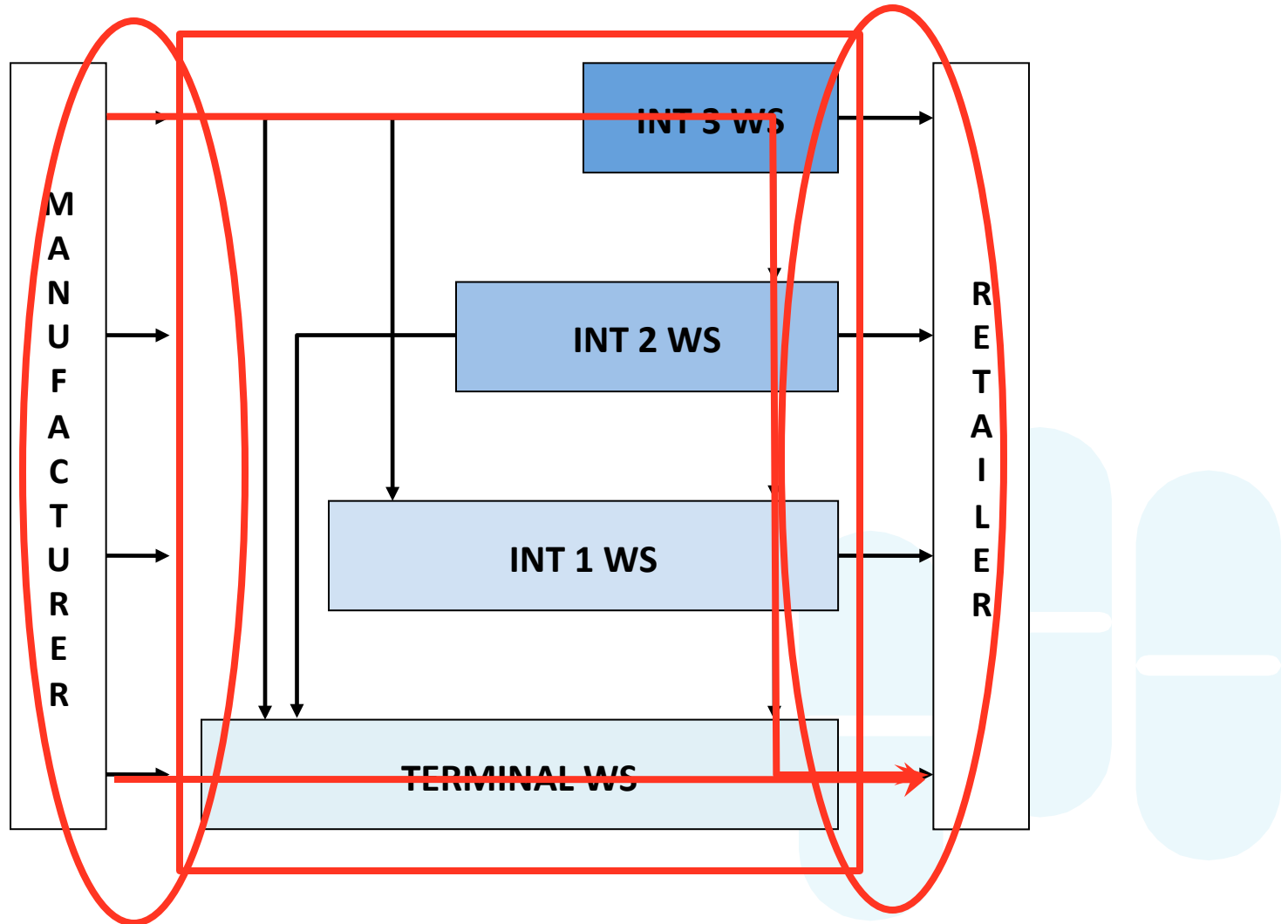

Antimalarial Distribution Chain Interactions

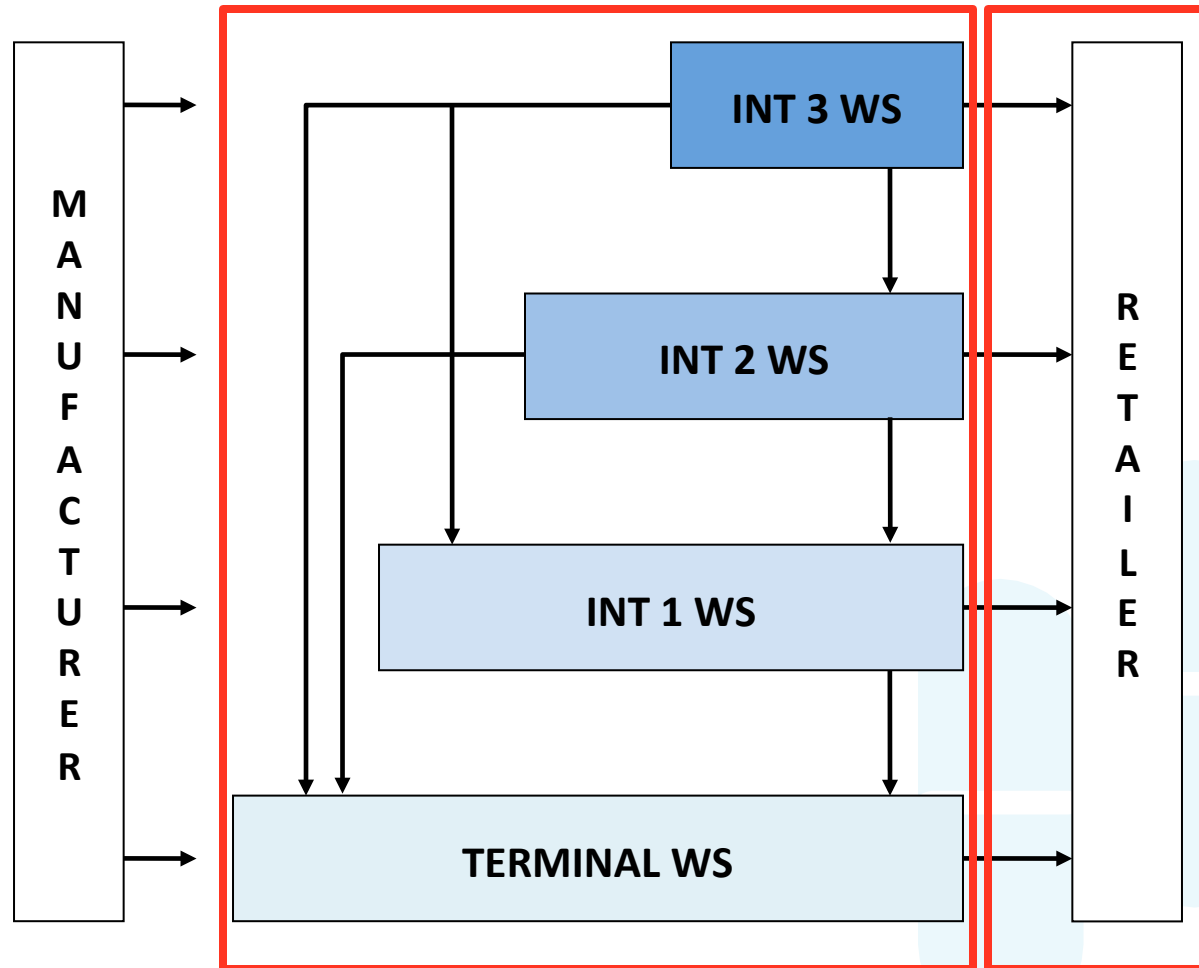

Supply higher levels: 19%

Supply retailers: 100%

Wholesale customers for antimalarials

- Most frequently cited customers at all supply chain levels included:
 - pharmacies/drug stores
 - drug wholesalers
 - private clinic/surgery/hospitals (commercial or mining)
 - public health centres
 - public hospitals
 - mission clinic /hospital

Antimalarial wholesalers that:	Supply Retailers	Supply Higher Levels
Sell to Medical Stores Limited	21%	50%
Sell to customers in other countries	15%	10%

Pharmaceutical Licensing

- The majority of wholesalers (WS) reported to have a wholesale pharmacy license:
 - WS that supply retailers: **75.6%**
 - WS that supply higher levels: **100.0%**

Antimalarial wholesalers that:	Supply Retailers	Supply Higher Levels
Import antimalarials	49%	90%
Reported to have pharmacy importer license	70%	90%
Sell to retail customers	57%	20%
Reported to have retail pharmacy license	28%	0%

Pharmaceutical Regulation & Provision of Credit

Antimalarial wholesalers that:	Supply Retailers	Supply Higher Levels
Had been visited by a pharmaceutical inspector in the past 1 year	98%	100%
Stored drugs in a dry area, out of direct sunlight & off the floor	86%	100%

- Wholesalers generally offered credit facilities to customers (median days of credit):
 - WS that supply retailers: **62.8%** (30 days)
 - WS that supply higher levels: **80.0%** (60 days)

Wholesale Availability of Antimalarials, ACTs & RDTs

■ Supply Retailers ■ Supply Higher Levels

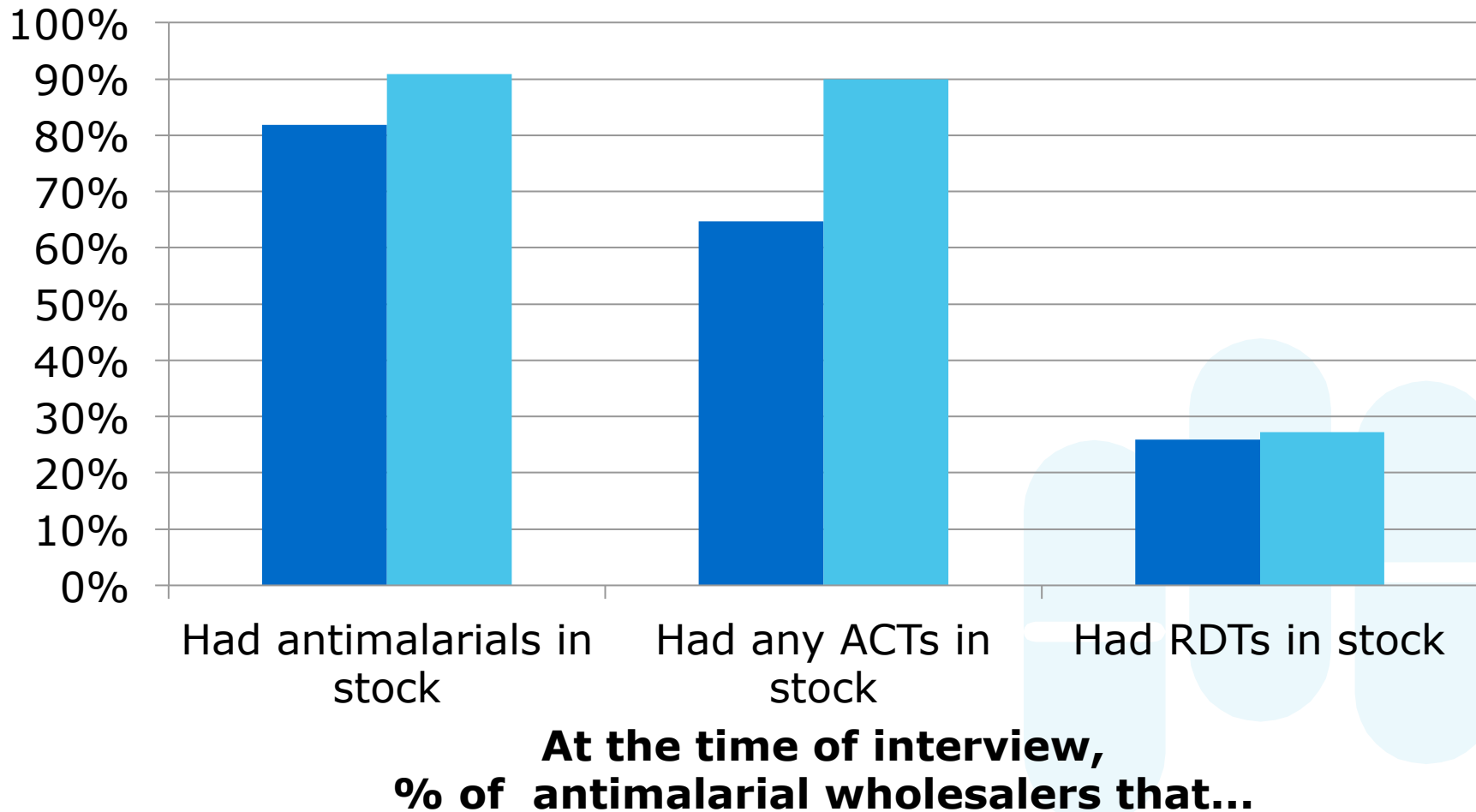

Wholesaler Knowledge & Practice

■ Supply Retailers ■ Supply Higher Levels

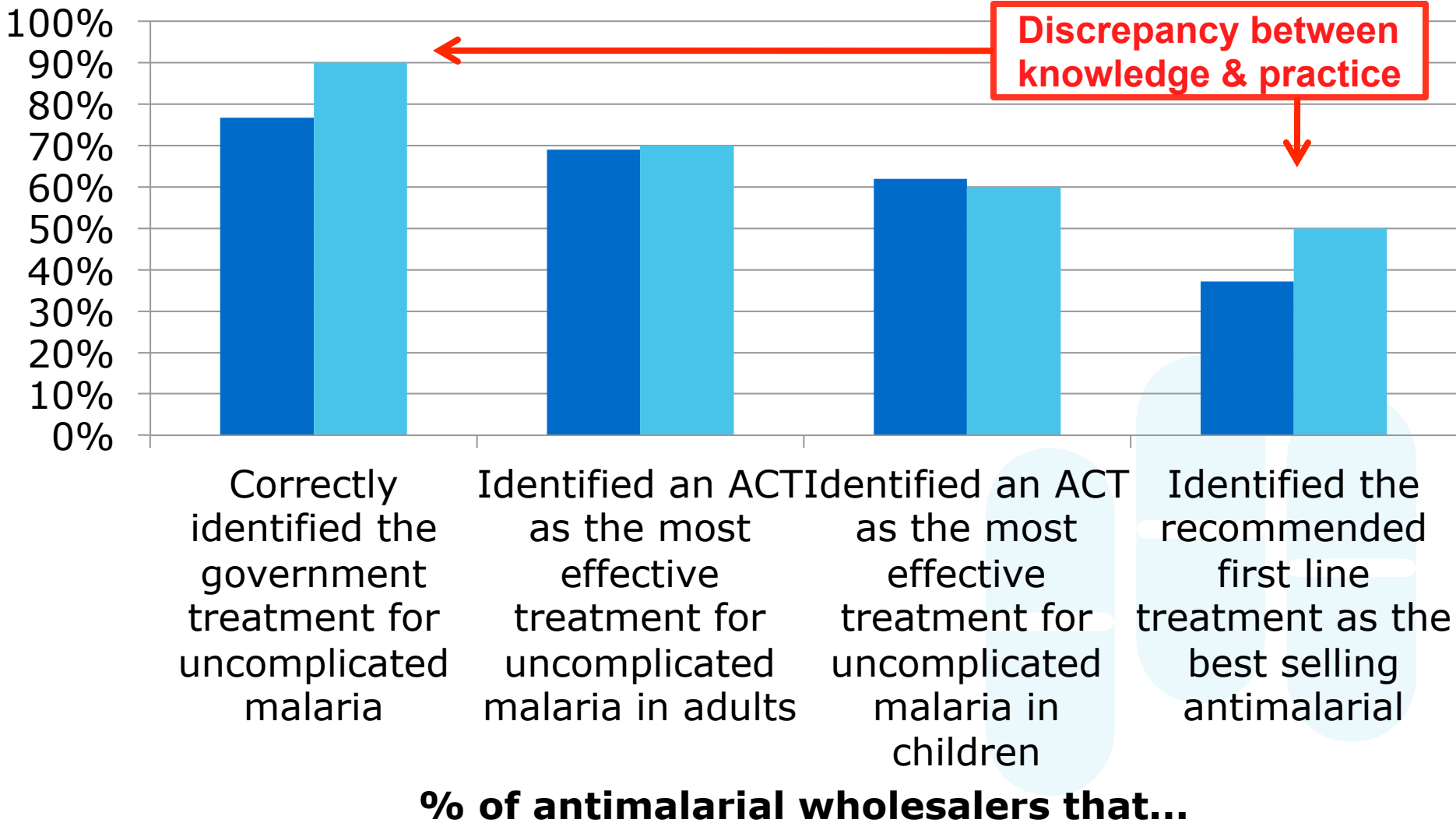

Median volumes in AETDs (n) sold in the past week by Wholesaler & Antimalarial Type

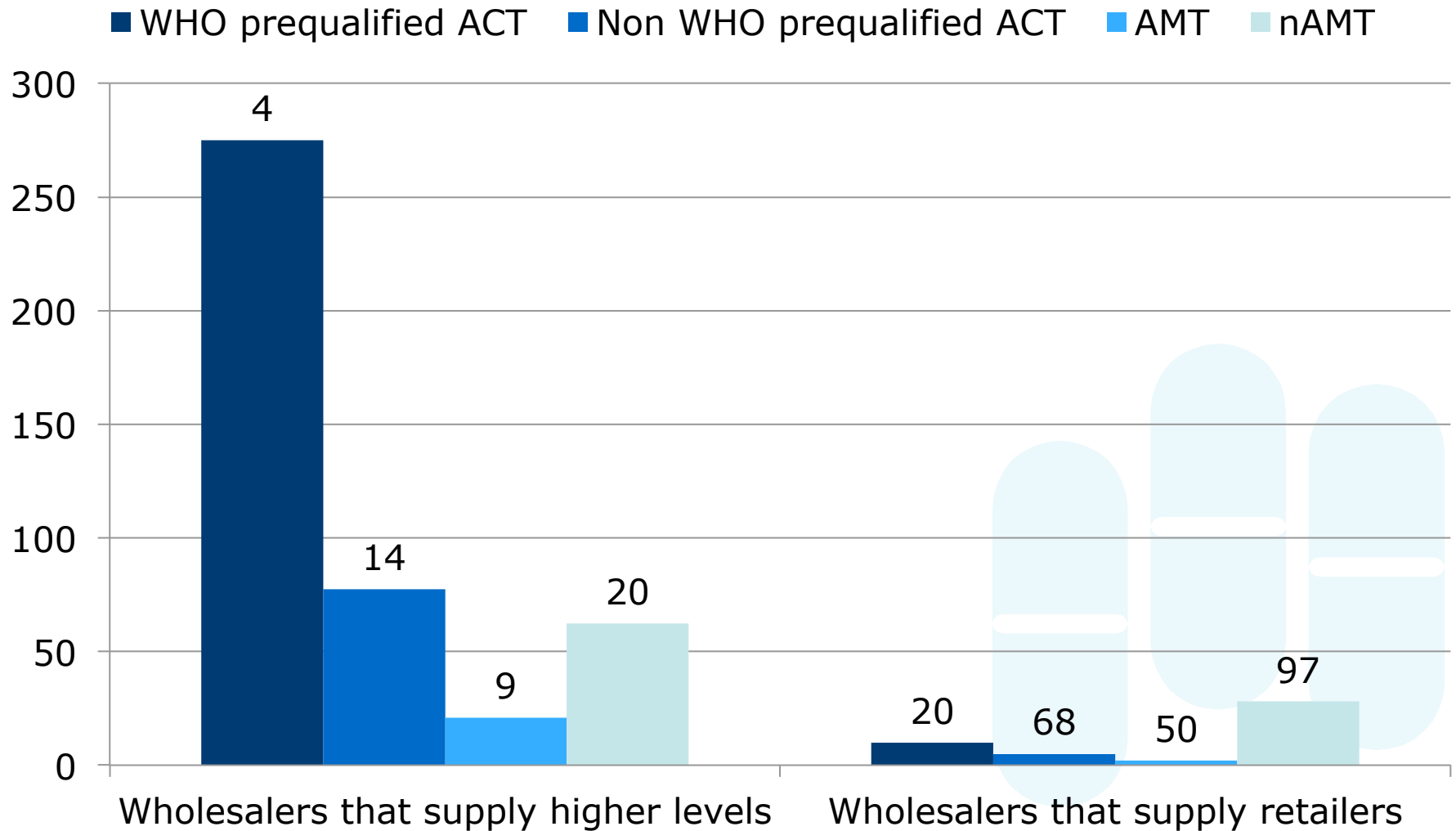

Median volumes in AETDs (n) sold in the past week by Wholesaler Type & Dosage Form

■ Tablet ■ Oral liquid ■ Injectable

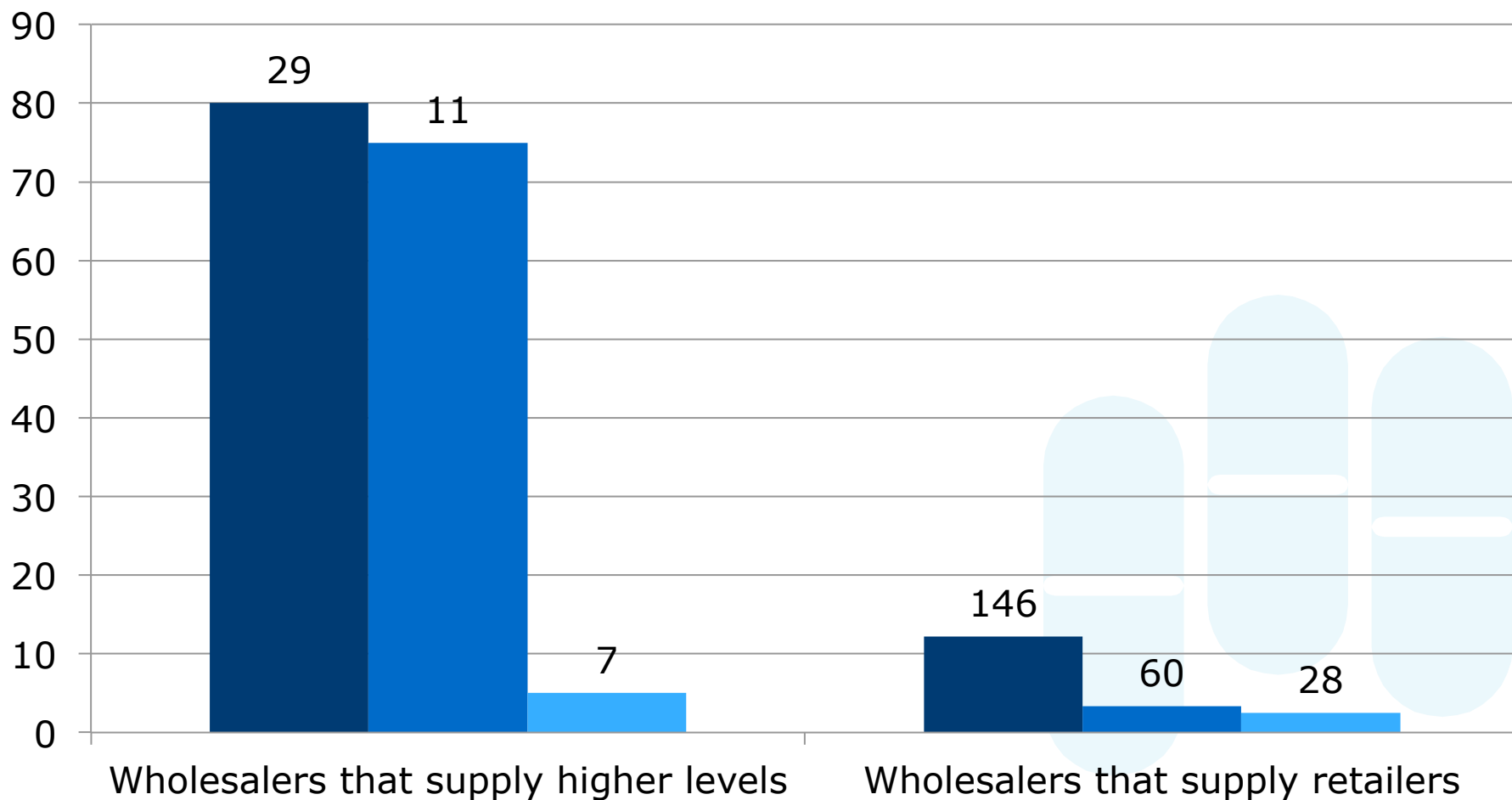

Median % Price Mark-Ups (n) by Provider & Antimalarial Type

- Wholesalers that supply higher levels
- Wholesalers that supply retailers
- Private retail outlets & providers
- Public health facilities

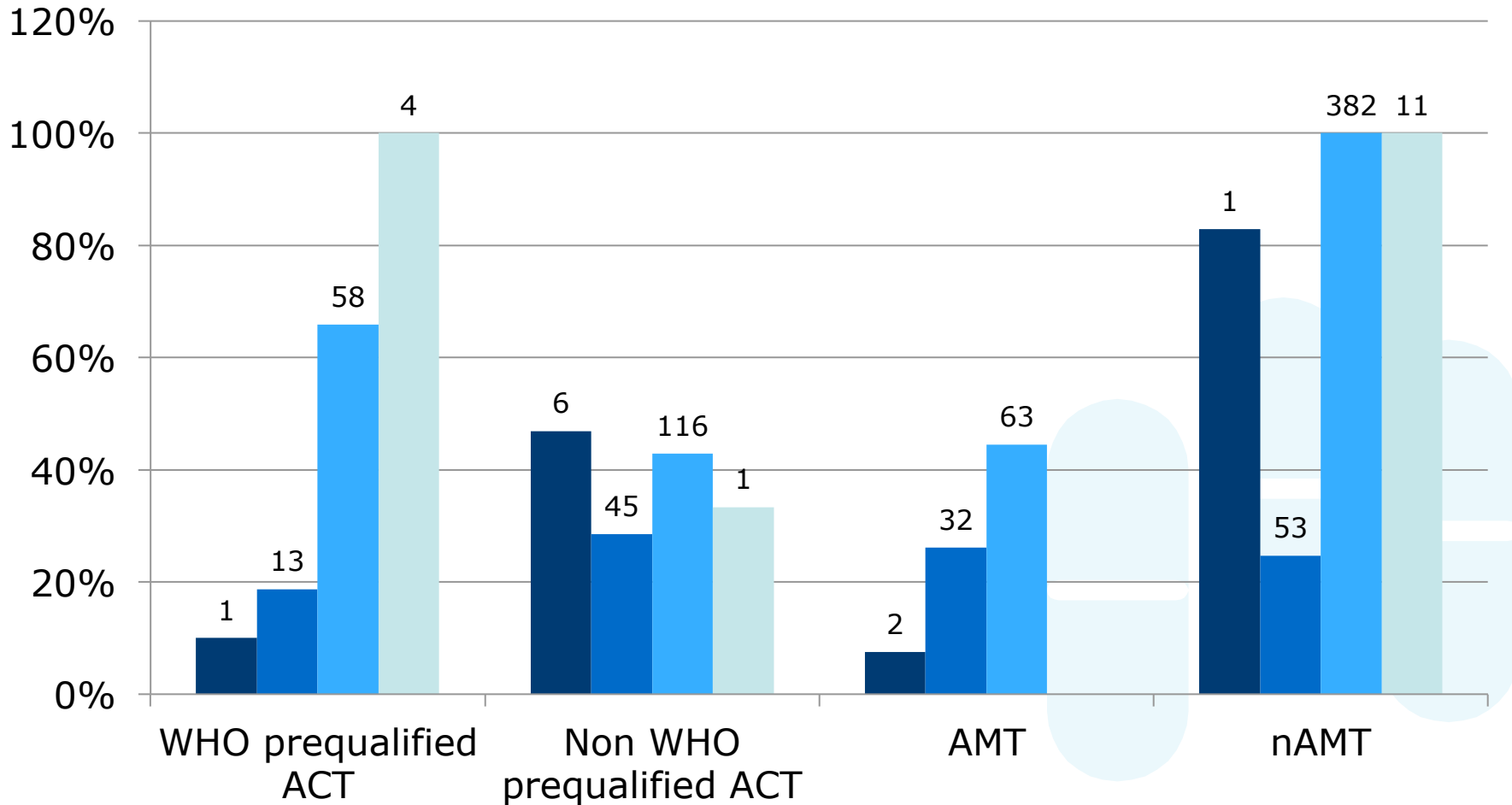

Median % Price Mark-Ups (n) among Private Retail Outlets & Providers by Antimalarial Type

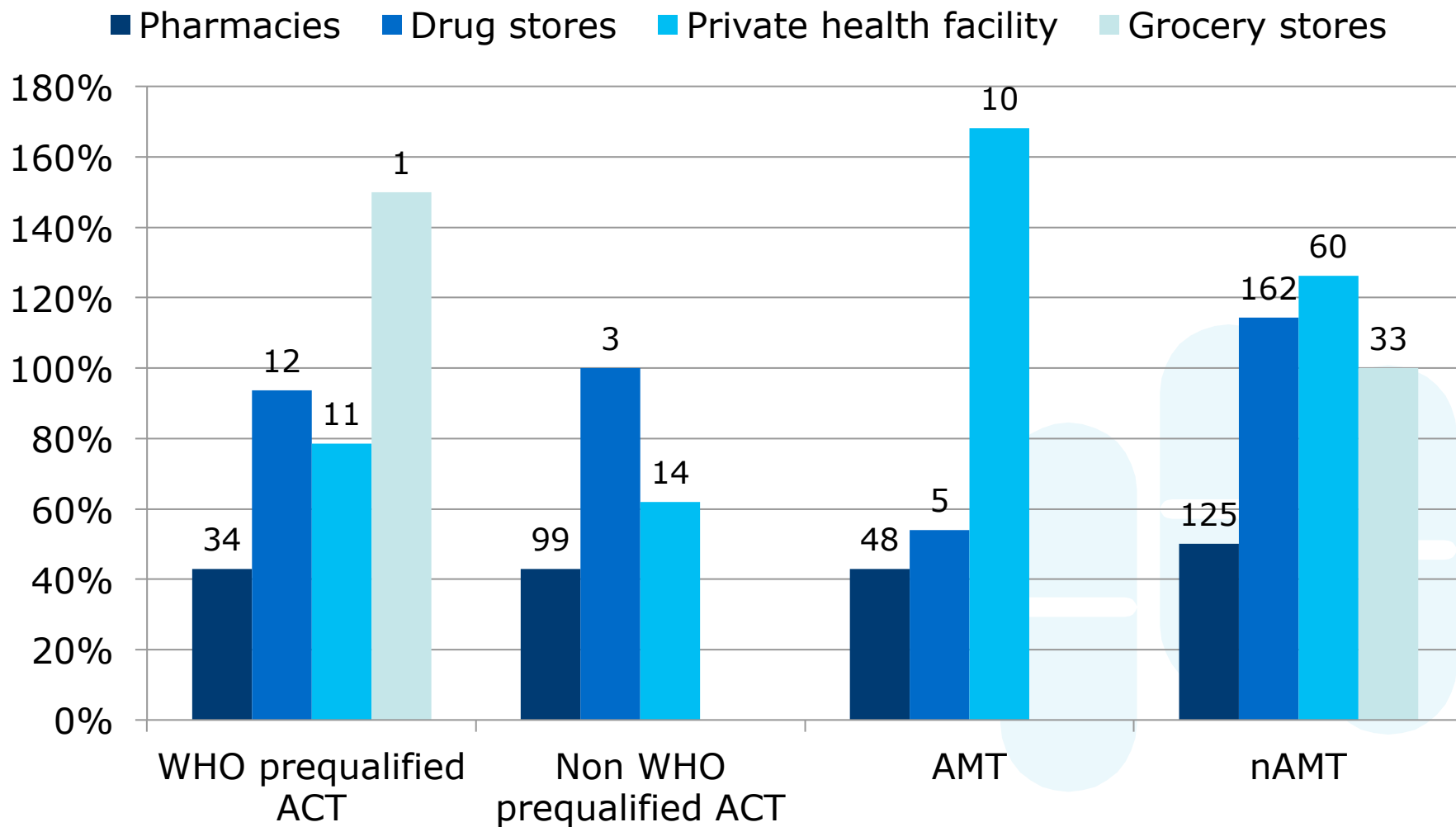

Median % Price Mark-Ups (n) by Provider Type & Dosage Form

- Wholesalers that supply higher levels
- Wholesalers that supply retailers
- Private retail outlets & providers
- Public health facilities

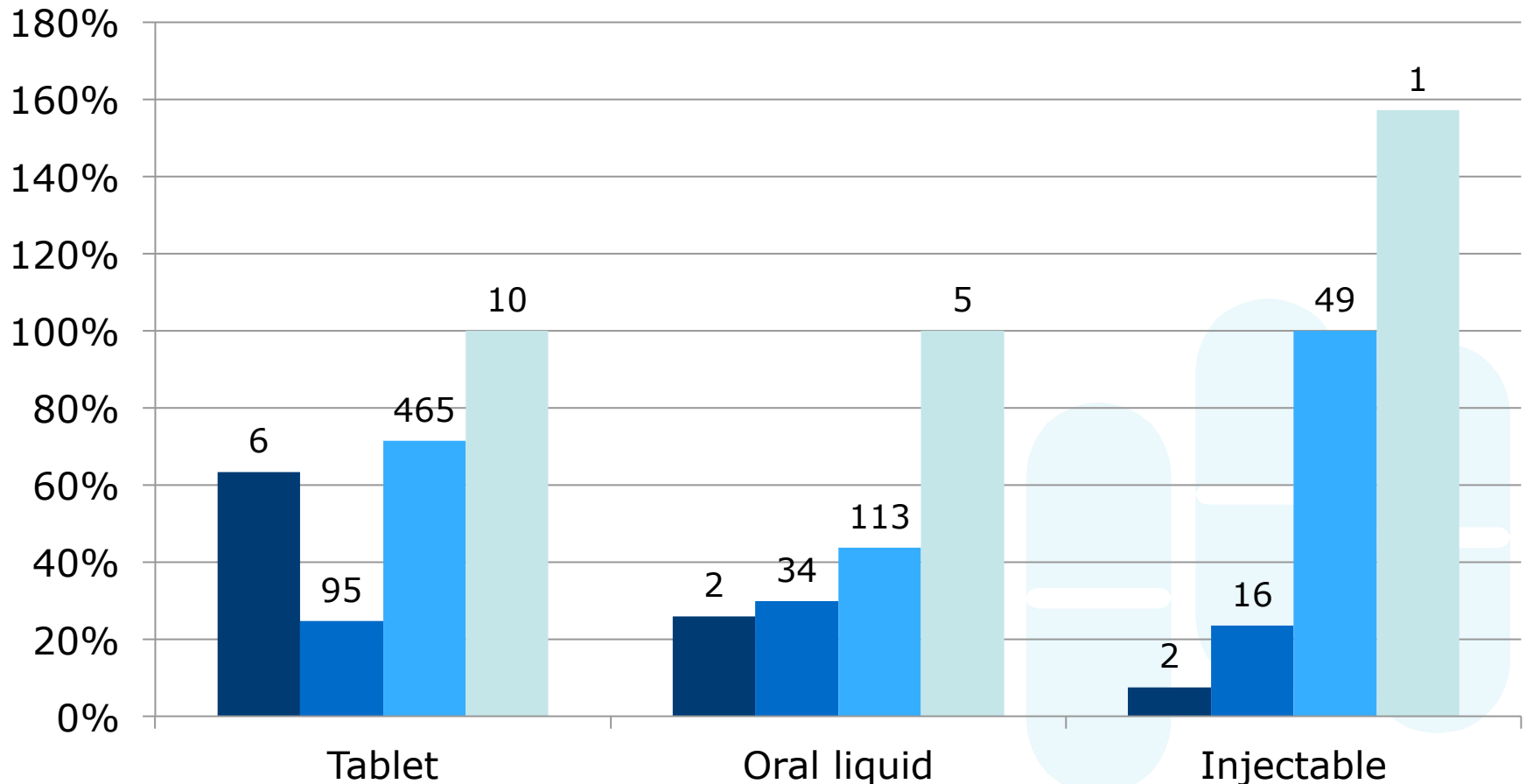

Factors Influencing ACT Access

Decision to stock

- Consumer demand
- Supplier price
- Product availability
- Perceived product effectiveness
- Recommended by government
- Authorised distributorships

Mark-ups

- Costs
- Volume of purchase
- Degree of competition
- Payment method
- Product availability
- Bonuses/discounts
- Product expiration date
- Type of antimalarial
- Authorised distributorships
- Other services offered

Next Steps

- Further investigate the determinants of wholesaler mark-ups and product availability
- Conduct comparative analysis of indicators across the ACTwatch countries



We acknowledge the valuable contributions of:

- ACTwatch Central Team
- In Zambia, we were assisted by SFH staff and NMCC

ACTwatch is funded by the Bill & Melinda Gates Foundation

**Please send any questions or comments to
benjamin.palafox@lshtm.ac.uk**

